

Geçmişten Günümüze Bakım

Ali Hançer
 Bakım İstanbul | The Green Park Pendik Otel | 02 Mayıs 2024

We pioneer motion



WHO AM I?

Ali Hançer

Proje Müdürü – Lifetime Solutions

Lifetime Solutions ürün portföyündeki projelerin satış, devreye alınması ve operasyonel yönetimi.

- Mekanik Bakım Mühendisi | Mercedes Benz | 2014-2017
- Üretim ve Proje Mühendisi | Toyota | 2018-2019
- Teknik Uzman, Türkiye & Azb. | Schaeffler | 2019-2022
- Proje Müdürü | Schaeffler | 2022-still

Schaeffler

SCHAEFFLER



1940s

~123,400
Çalışan

~200 Lokasyon
~54 Ülke

82 Fabrika
20 ArGe Merkezi

>1,000
Kayıtlı patent | 2023

7.3%
EBIT | 2023¹

~€16.3 Milyar
Satış | 2023

SCHAEFFLER

????

Geçmiş

Gelecek

Günümüz

Günümüzden Geçmişe Bakım Stratejileri





Yağlamanın Tarihi

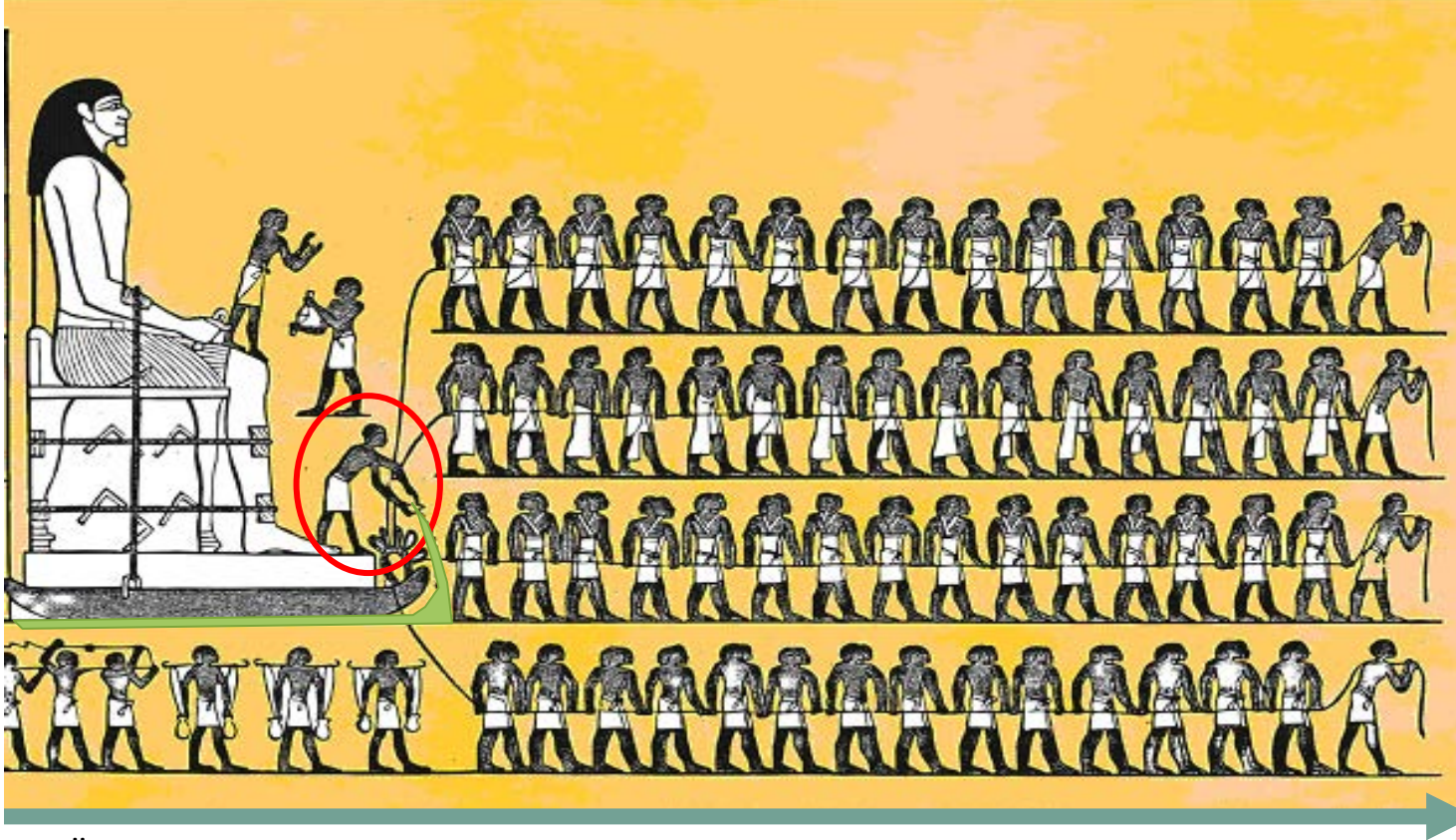

- M.Ö 2400 : Ti'nin heykelinin bitkisel ve hayvansal yağlar ile taşınması.
- Tehut-Hetep'in mezarı.

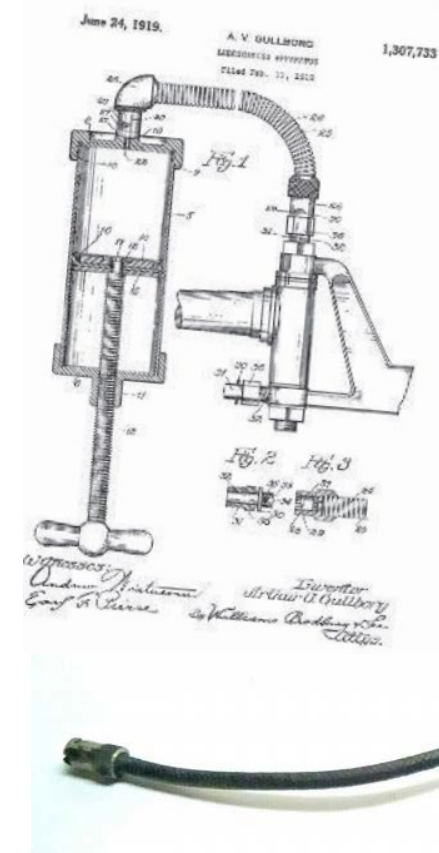

1916

-Arthur Gulborg

Peki bu şekilde yağlamanın sonuçları neler?

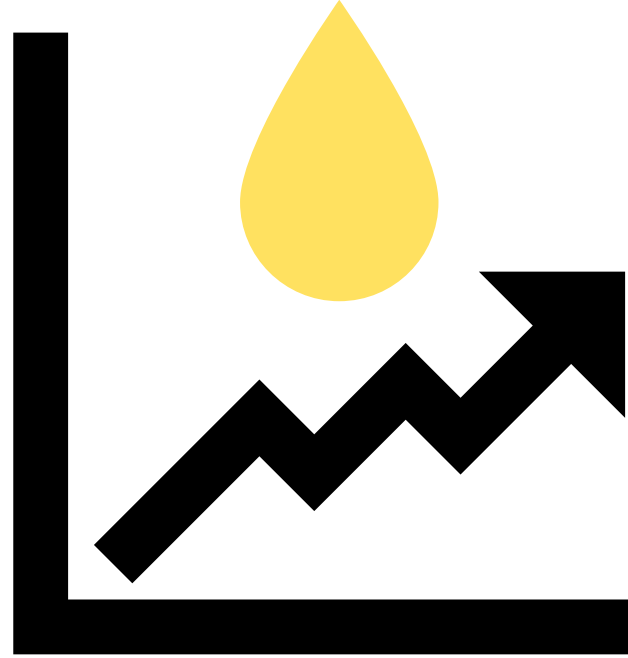
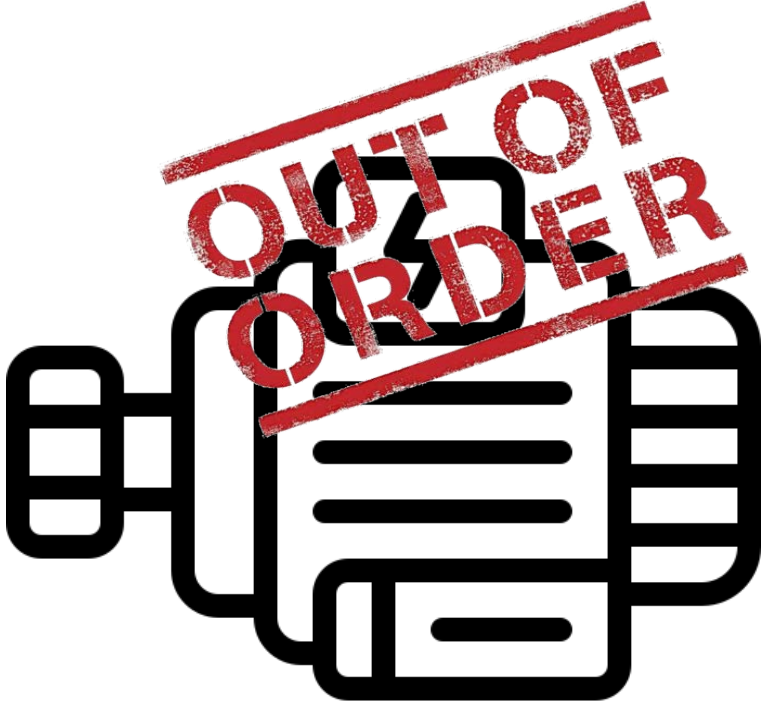



Durum İzlemenin Önemi

- Plansız duruşlar
- Üretim kayıpları
- Bakım maliyetleri
- İkincil hasarlar
- Arızayı analiz etmek
- Daha iyi planlama
- Ekip verimliliği
- Onarım imkanı

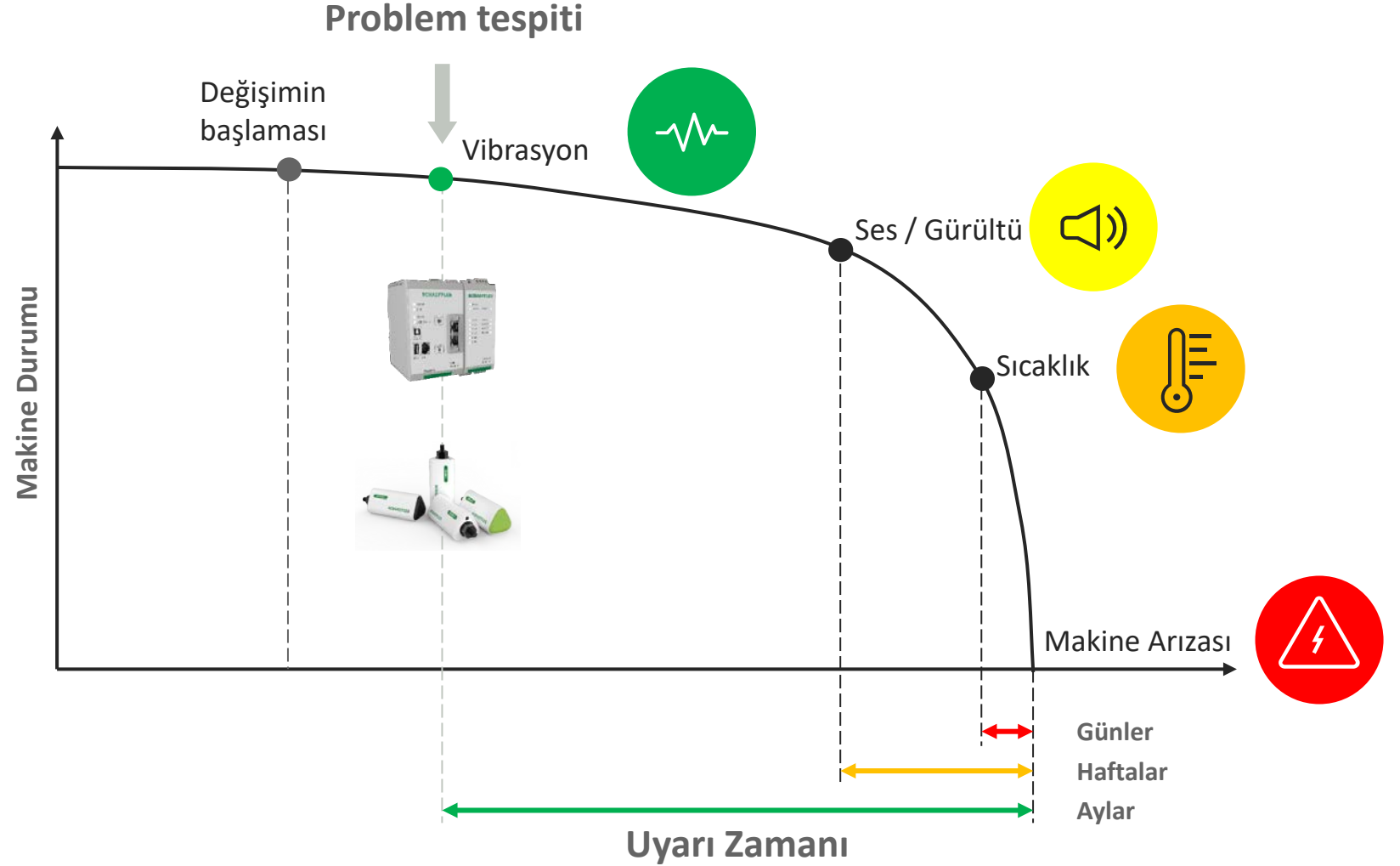

Vibrasyon Tarihindeki İlkler

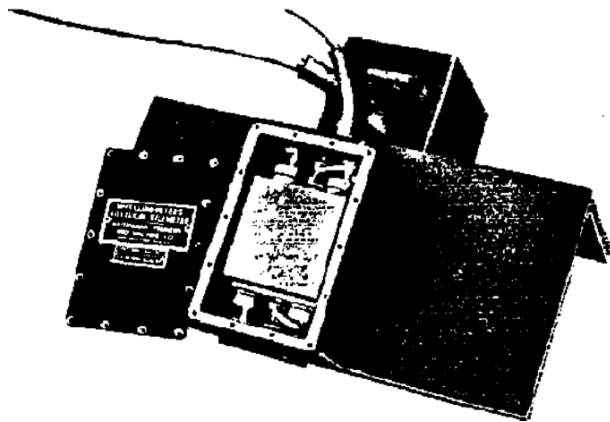
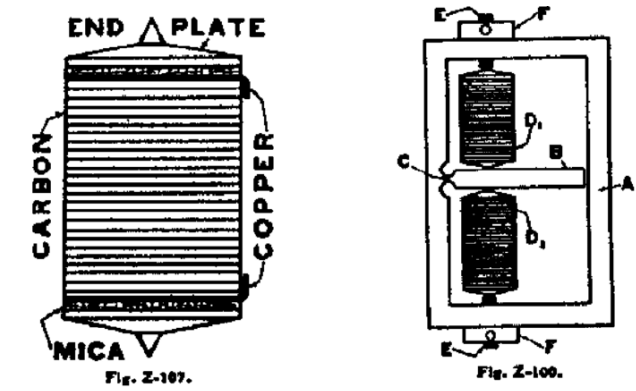
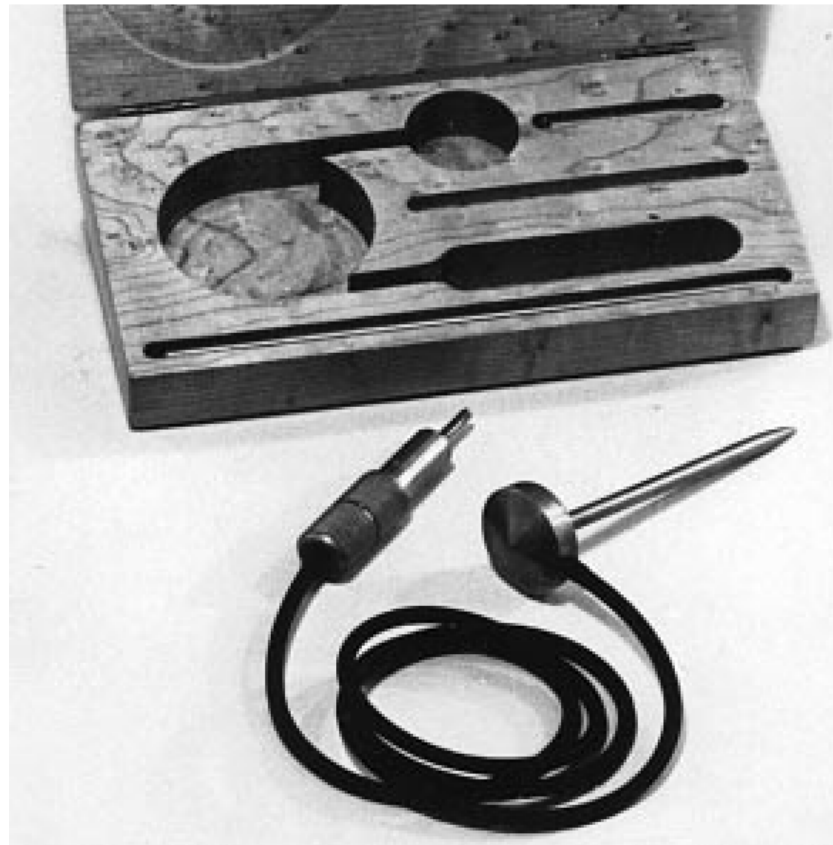

Fig. 2652.
Accelerometer.
Double type.

1936



1943



1975

QUALITY

EFFICIENCY

COST



Günümüze Bakalım



Günümüze Bakalım

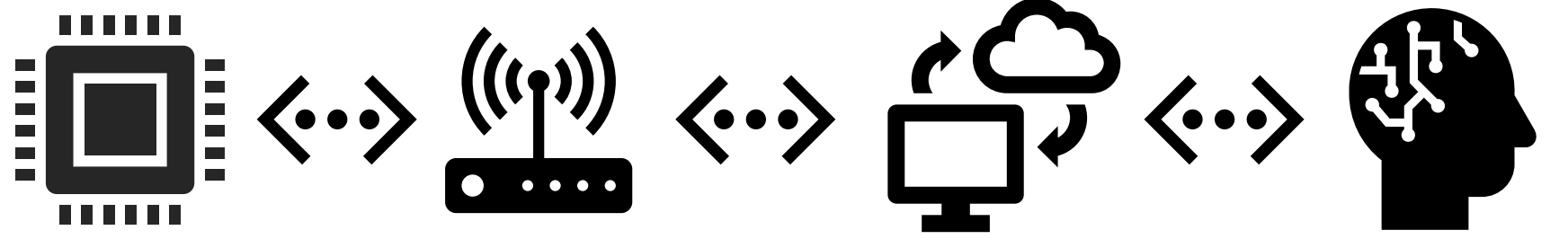
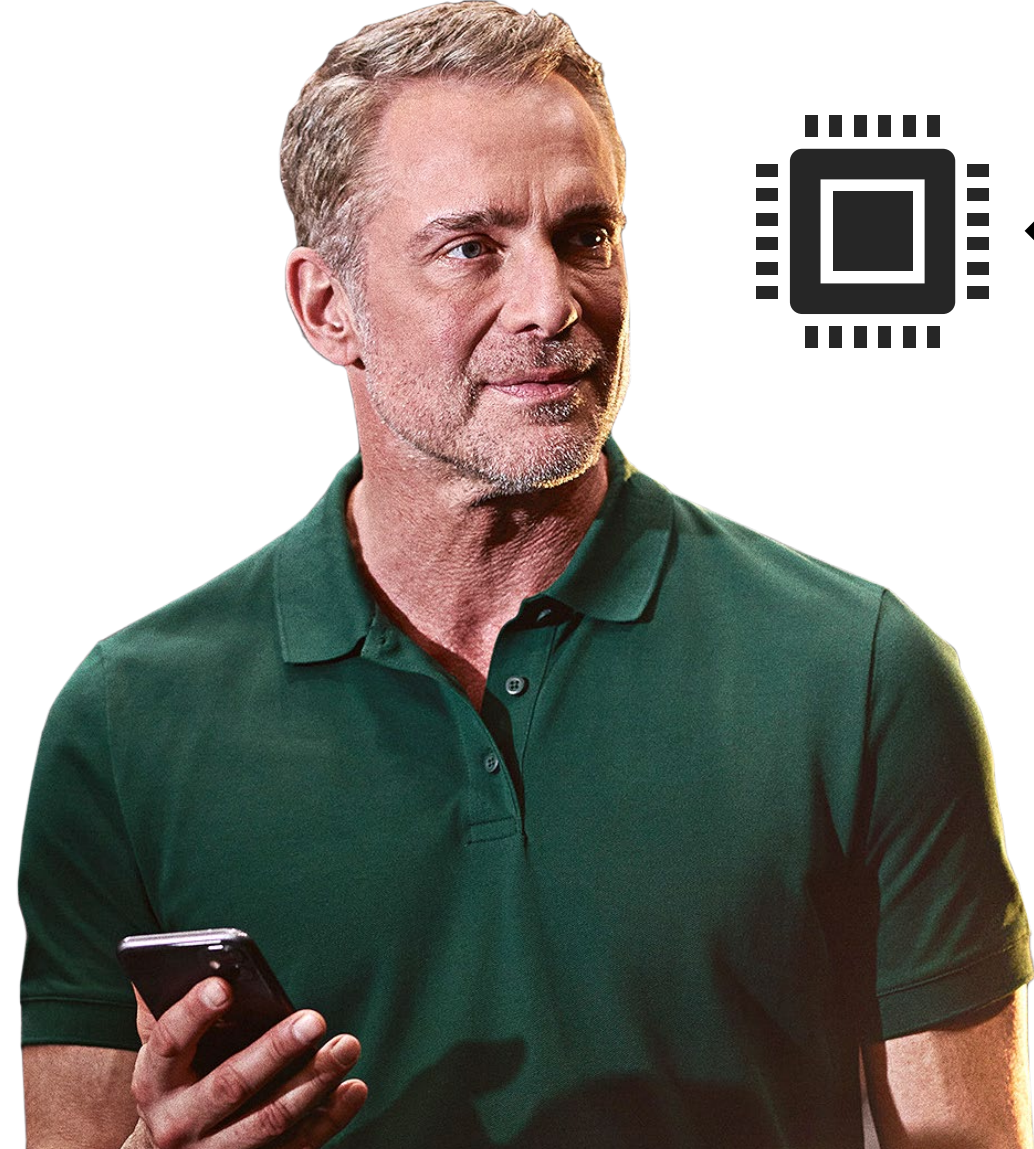

Schaeffler Çözümleri



ProLink Çok Kanallı Durum İzleme Sistemi

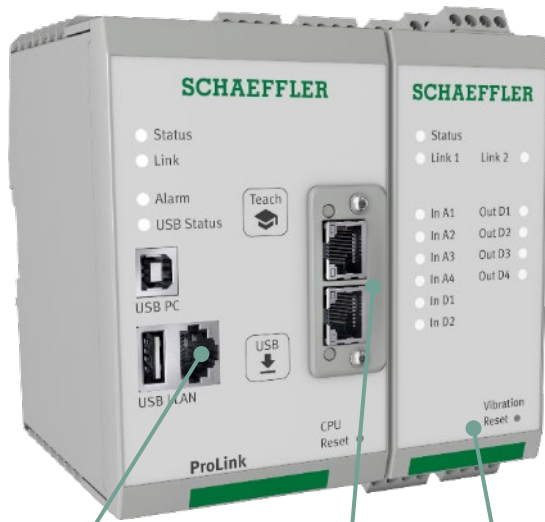

Additional modules

- individually expanded with additional measurement modules

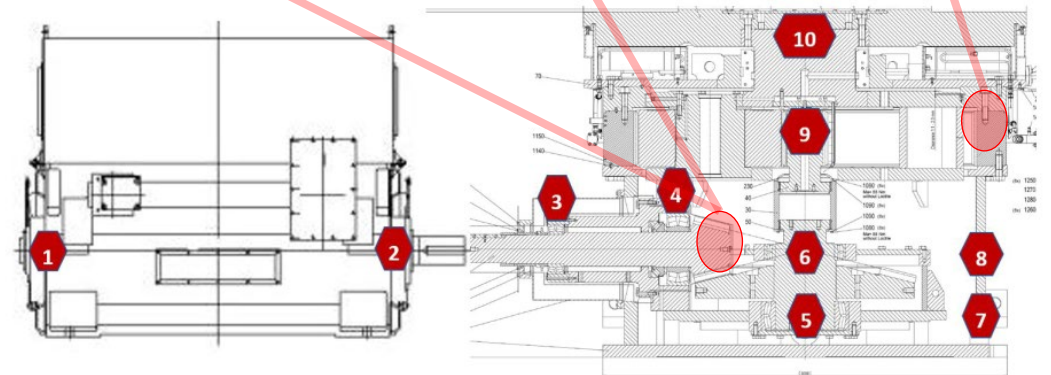
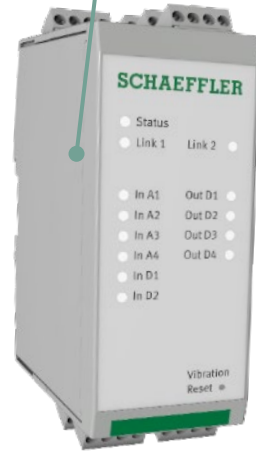

Cloud-Communication

- Ethernet
- OPC-UA Server, MQTT, Webservices

Field bus connection*

- Profinet,
- CC-Link IE,
- Ethernet/IP
- ...

Vibration module with recording of speed data

- Extremely high signal quality (24 bit)
- High-quality signal processing

> 2M



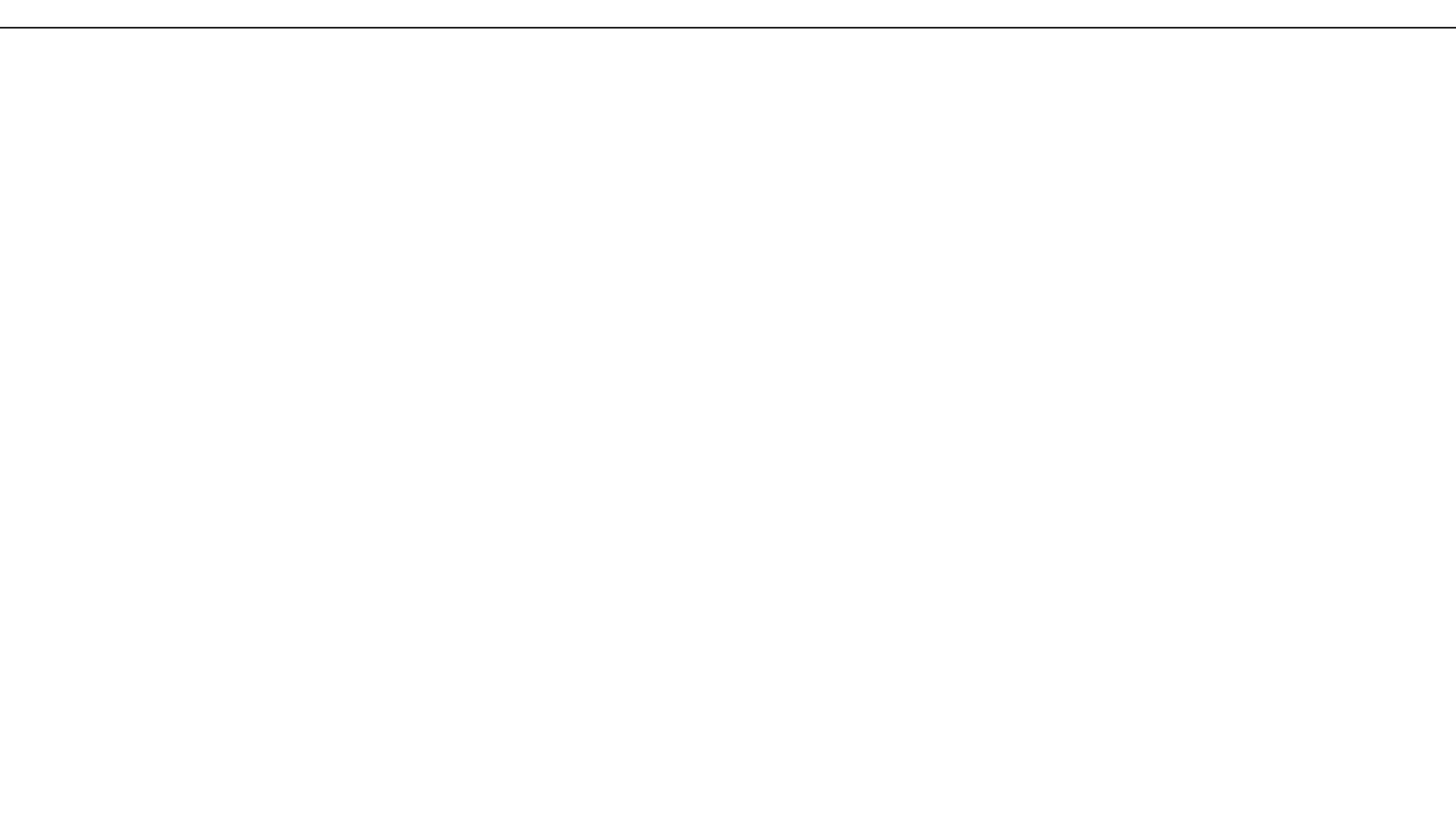

Optime C1 Akıllı Yağlama Sistemi

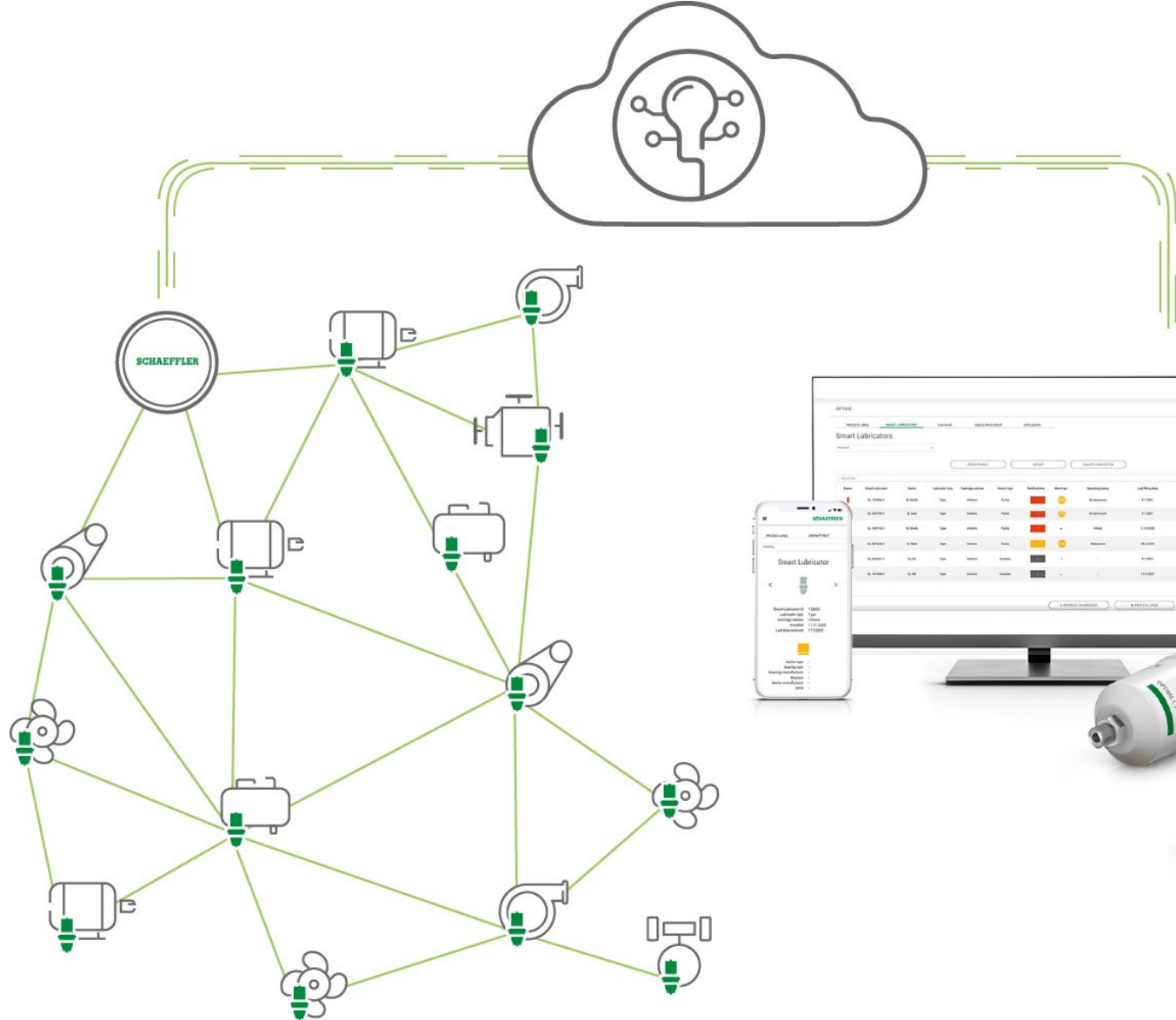

Optime Ekosistemi

15:03

SCHAEFFLER

Measuring points (4)

Fan Serbest Taraf

Fan Tahrik Taraf

Motor Arka Taraf

Motor Ön Taraf

Add sensor

Lubricators (2)

C1-083 SERBEST

C1-083 TAHRIK

Add lubricator

15:02

SCHAEFFLER

İN-1 ÜNİTESİ/C1-083 KLİNKER SOĞUTMA FANI-3

C1-083 KLİNKER SOĞUTMA FANI-3

Machine name -

Machine type -

Show all

Machine status

No condition data available yet

Motor Arka Taraf 2023-09-26 03:01 Probably bearing damage

Motor Ön Taraf 2023-09-28 07:02 Probably bearing damage

Show all

Notifications (18)

C1-083 KLİNKER SOĞUTMA FANI-3 2023-09-26 03:01 Machine status is warning

C1-083 KLİNKER SOĞUTMA FANI-3 2023-09-25 12:57 Machine status is suspect

15:02

SCHAEFFLER

Status: Warning

C1-083 KLİNKER SOĞUTMA FANI-3

1 ÜNİTESİ/C1-083 KLİNKER

Bearing damage Bearing damage

C2-190 FULLER POMPA - DF2 KAFA VE KALSİNATÖR KÖMÜR SİLOSUNA

2 ÜNİTESİ/C2-190 FULLER KÖMÜR SİLOSUNA

D2-022-LB / Lastik Bantı

LOESCHE ÜNİTESİ/D2-022-LB /

EĞİPMAN AD

12:28

SCHAEFFLER

C2-061 SERBEST

Machinery

Lubricator ID: 66383310

Lubricator serial number: LW1-22222068109

Lubricator type: OPTIME LW1

Cartridge designation: RETURABLE

Cartridge material number: 09316076-000610

Lubricant type: none / empty

Cartridge volume: 125.0 cm³

Number of outlets: 1

Gas release setting: 7.1

Lubricant quantity: 125.0 cm³ in 7 month(s)

Lubricator last used: 2023-09-28 05:26:03 PM

Data received: 2023-09-19 4:52:56 AM

6%

Normal

Almost empty

Empty

Operating status: Normal

Battery level: 100%

12:28

SCHAEFFLER

All lubricators

C2-190 TAHRIK 7%

F1-230 SERBEST 7%

F1-230 TAHRIK 7%

C2-190 SERBEST 90%

12:28

SCHAEFFLER

All lubricators

C2-190 SERBEST 6%

C2-061 SERBEST 6%

C2-061 TAHRIK 6%

K2-070 SERBEST 50%

K2-070 TAHRIK 82%

12:28

SCHAEFFLER

All lubricators

F2-124 TAHRIK 33%

K2-070 SERBEST 50%

C1-082 SERBEST 41%

C1-082 TAHRIK 41%



Optime Ekosistemi

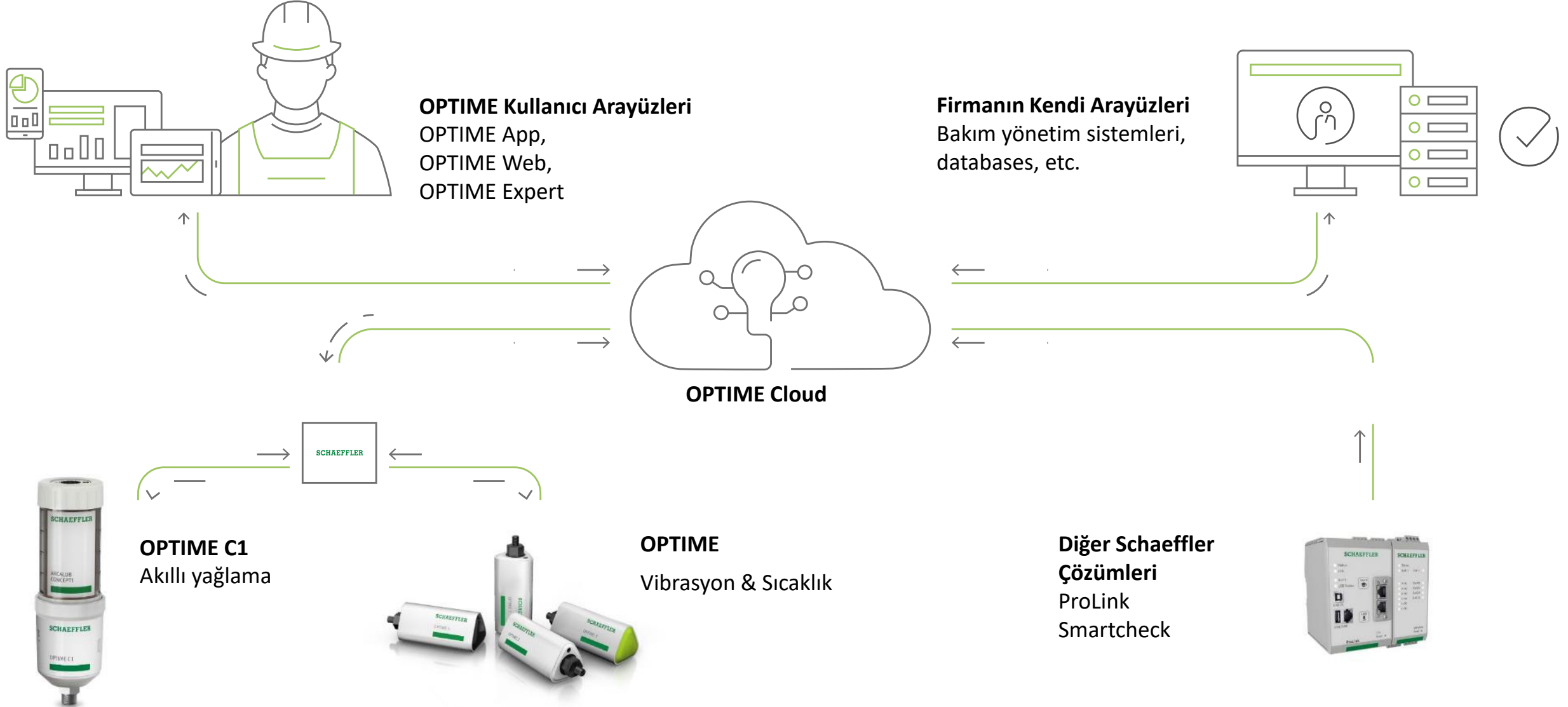

Schaeffler Lifetime Solutions

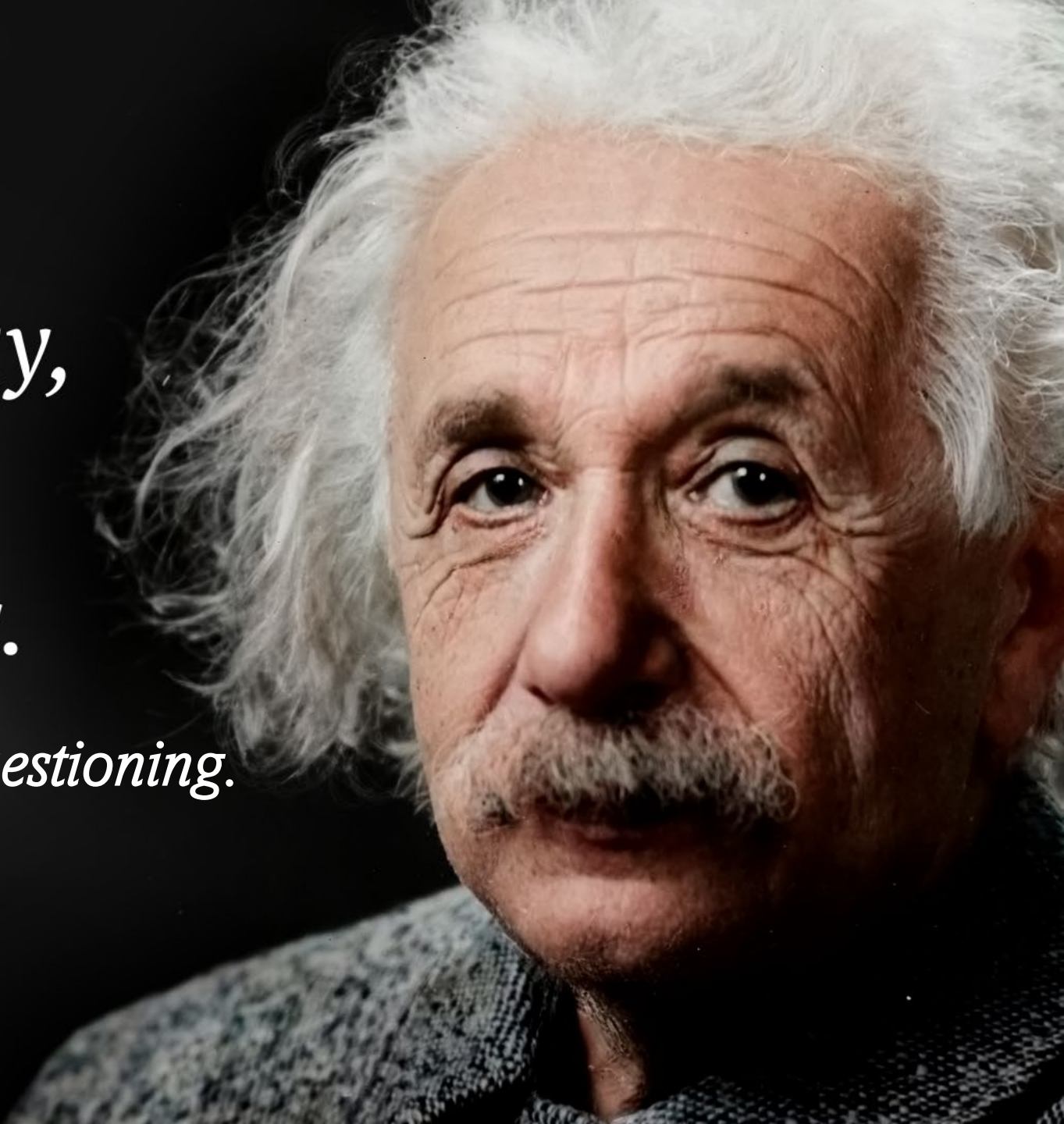

A close-up portrait of Albert Einstein, showing his characteristic wild white hair and mustache. He is looking directly at the camera with a thoughtful expression. The background is dark, making his face the central focus.

*Learn from yesterday,
Live for today,
Hope for tomorrow.*

The important thing is not to stop questioning.

ALBERT EINSTEIN

Theoretical physicist, 1879–1955

